



Supercrete

Block Construction

**Sound Insulation • Quality
Thermal Insulation • Fire Resistant**



- 
- 
- 
- 
- 
- 
- 
- 
- 
- 
- 
- 
- 

Hebel

Supercoat

What is Hebel Supercrete Block Construction?

Hebel Supercrete Blocks are manufactured from Autoclaved Aerated Concrete (AAC). This is made from lime, sand and cement, to which a frothing agent is added to aerate the concrete. The partially cured concrete is then autoclaved to complete the curing and to promote the formation of a crystalline structure. The aeration and low density (approximately one quarter of the density of standard reinforced concrete) enables blocks to be easily cut, drilled and shaped by hand. Blocks are glued together to form solid masonry structural walls with excellent thermal and acoustic properties.

Benefits

- The block construction system is very simple yet allows complete design flexibility for basic or complex designs and architectural features.
- Construction can be undertaken by anyone familiar with standard construction methods and does not have to be undertaken by block or bricklayers.
- Solid wall construction gives a quality and feel to a building that is normally associated only with elite homes at the top end of the market.
- Independent cost comparisons show that Hebel Supercrete Block is very cost efficient and affordable, compared with other solid masonry systems.
- Hebel Supercrete Block does not rot or decay over time, does not support the growth of fungus or mould, and does not harbour rodents or insects.
- Block construction has all the inherent thermal, acoustic and fire resistant benefits of AAC. All walls 150 mm thick or more have a 4-hour fire rating, the highest rating possible.
- Hebel Supercrete Block construction can be complemented with Hebel Supercrete Floor Panels, stair treads, and wall panels.
- As blocks are glued together, they form homogeneous panels with uniform thermal and acoustic properties over the whole wall surface.
- The low density of Hebel Supercrete Block gives a high strength to weight ratio, with a reduced bracing demand. Hebel Supercrete Block buildings have performed well under actual earthquake conditions.
- Hebel Supercrete Block can be used for internal and external walls, load-bearing walls and for multi-storey construction.

Components

- Hebel Supercrete Blocks for structural purposes are available in a full range of thicknesses from 150mm, through to 300 mm. All blocks are solid unreinforced AAC with a dry density of 550 kg/m³ (approximately the same as Douglas Fir timber) and are 550 mm long by 200 mm high. Blocks are dimensionally very accurate as they are cut to size when partially cured.
- Supercoat Superbond Adhesive is a modified cement mortar supplied in dry powder form in 20 kg bags. It is applied to joints in a 2 –3 mm thickness
- Precast Hebel Supercrete lintels are available in a range of sizes and thicknesses for openings up to 2.4 metres wide, and are constructed of the same AAC material as the blocks. Larger openings can be accommodated by using the Hebel Supercrete as formwork, and pouring concrete lintels insitu.
- Vertical reinforcing rods are installed into drilled holes in the blocks at nominal 1.0 metre centres. These threaded galvanized rods are supplied in 3 metre lengths, and can be joined with coupling nuts as required.
- Supercoat Superbase render is available for finishing of block walls. This is a plaster mix of graded fine sand, cement and lime, modified with fibres, water entrainers & plasticisers. It is strength matched to Hebel Supercrete Block, and produces a high quality finish with relative ease. It is normally applied in 2 coats with a finished thickness of only 6 to 16 mm.
- Hand tools are available for use with the Hebel Supercrete Block including notched trowels, drill bits, sanding floats and saws.
- Fasteners especially designed for use in Hebel Supercrete Block are available from Hilti, Tox and Ramset. These are typically of the expansion type.



Design Considerations

Foundation design should be in accordance with NZS 4229 for full masonry design. Typical footing details for block walls are shown in Detail 1.

The minimum recommended thickness of walls is 200 mm for external and 150 mm for internal load bearing walls.

As with all solid masonry construction, it is advisable to align walls on upper floors with those on lower floors, to avoid the requirement for support beams.

Bracing capacity of walls should be calculated using the bracing tables in the Hebel Supercrete Technical Manual. Vertical reinforcing in these tables is at nominal 1.0 metre centres and the top of all walls on each level should have a bond beam constructed with 2/D12 rods minimum. Bond beam construction is shown in Detail 2. Where this supports a floor, refer Hebel Supercrete Structural Floor Panel detailing.

Vertical movement control joints are required in all walls at a maximum of 6.0 m spacing. See Detail 3 showing control joint construction. Vertical control joints should

also be aligned with floor slab joints, changes in foundation supports or wall heights, and at likely stress raiser points in the floor shape. The location of control joints should be established prior to calculating bracing capacity of the building. Note that if it is intended to only construct the exterior walls using Hebel Supercrete Block, it is usually advisable to include some internal block walls to increase the bracing capacity.

Hebel Supercrete Block is much more dimensionally stable than timber or poured concrete with varying temperature or moisture content. Wherever Hebel Supercrete Block is to be installed adjacent to different materials, provision should be made for incorporating a slip joint to enable relative movement between the dissimilar materials.

If precast lintels are to be used, a minimum wall height of 2.6 metres will be required for a window head height of 2.0 metres, to enable the lintels to be fitted under the bond beams. Lower wall heights will require cast insitu lintels.

Construction plans should detail the location of vertical rods and the location of movement control joints.

Detail 1. Typical Foundation Detail

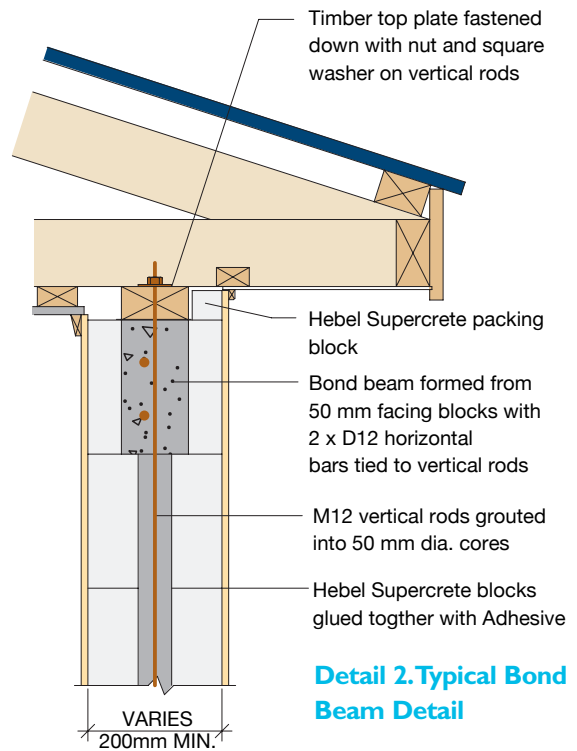
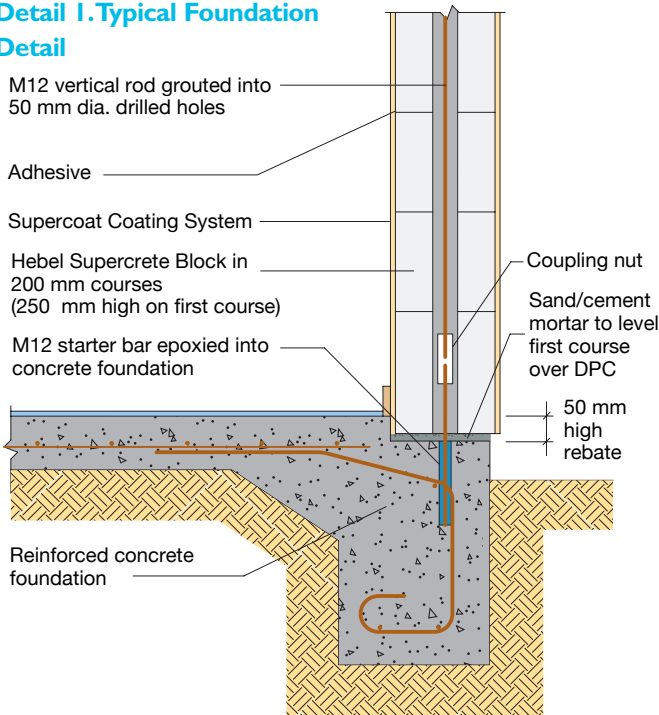

Detail 2. Typical Bond Beam Detail

Detail 3. Movement Control Joint Details

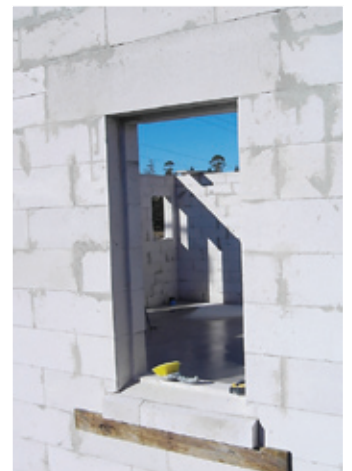
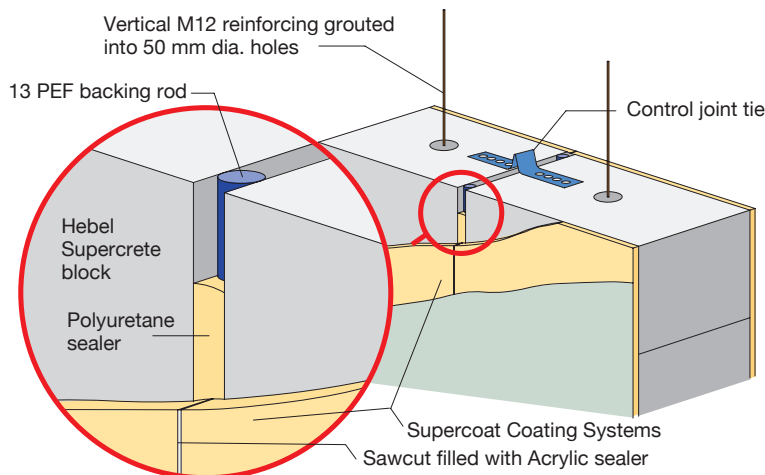

Ordering, Delivery and Storage

Your local Supercrete Distributor will provide a full schedule of quantities of all components required for the Hebel Supercrete Block part of a building. There is a lead-time of approximately 4 - 6 weeks required from time of order to delivery on site. Supercoat Superbase render has a 6 month shelf life and it is often advisable to order this at a later date than the block.

Hebel Supercrete Block is supplied plastic wrapped on pallets and should be kept as dry as possible prior to laying. It is advisable to place these pallets as close as practical to the areas where the block is to be used for faster construction and reduced labour. Floor slabs should be cured for a minimum of 7 days before placing pallets directly on them. Supercoat Superbond Adhesive and Supercoat Superbase render should be stored under cover.

Construction

Overall wall construction is shown in Detail 6. Threaded starter rods are epoxied into drilled holes in the foundation rebate. A layer of DPC is laid along the rebate to provide a slip joint for the Hebel Supercrete/ concrete interface. A nominal 10 mm layer of it's mortar is trowelled over the DPC and the first course of 250 mm high blocks is placed and leveled to string lines, beginning at corners. Cutouts for access to the starter rods are drilled and cut from blocks as laying proceeds.

Blocks can be cut using a handsaw or a band saw. Extra care should be exercised laying the first course to provide a good level base for subsequent courses. Blocks are drilled for the vertical rods as the laying proceeds and glued in place, with minimum overlap of 100 mm, using Supercoat Superbond Adhesive. The surface of each course should be brushed off to remove all dust before adhesive is applied and the surface of blocks should be kept dry. All excess adhesive should be smoothed off on both sides of the wall before it goes hard.

Once the top block course under the bond beam has been reached, the threaded vertical rods are dropped down the drilled holes and screwed into the coupling nuts on the starter rods. Access cutouts are glued back in place, and the vertical cores are then grouted with 15 MPa minimum grout.

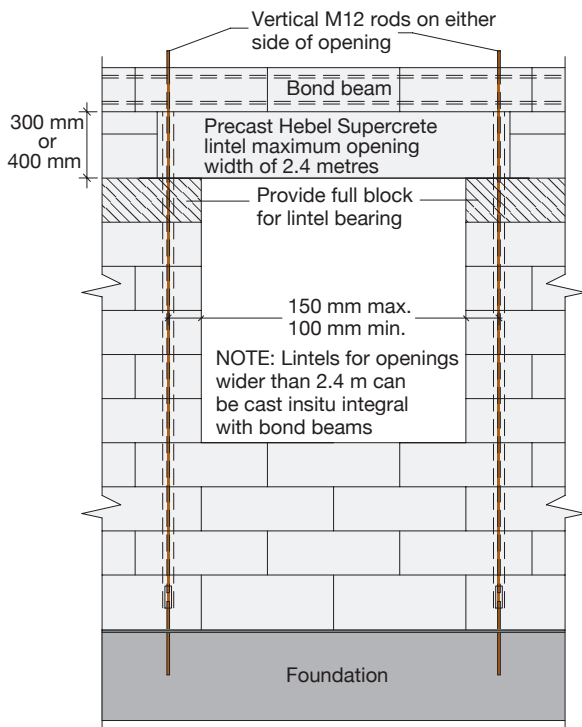

Detail 4. Typical Lintel Detail

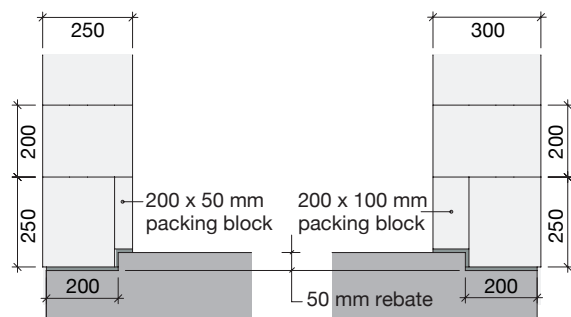

Detail 5. First Course Detail for Varying Wall Thickness

Detail 6. General Arrangement of Wall Construction

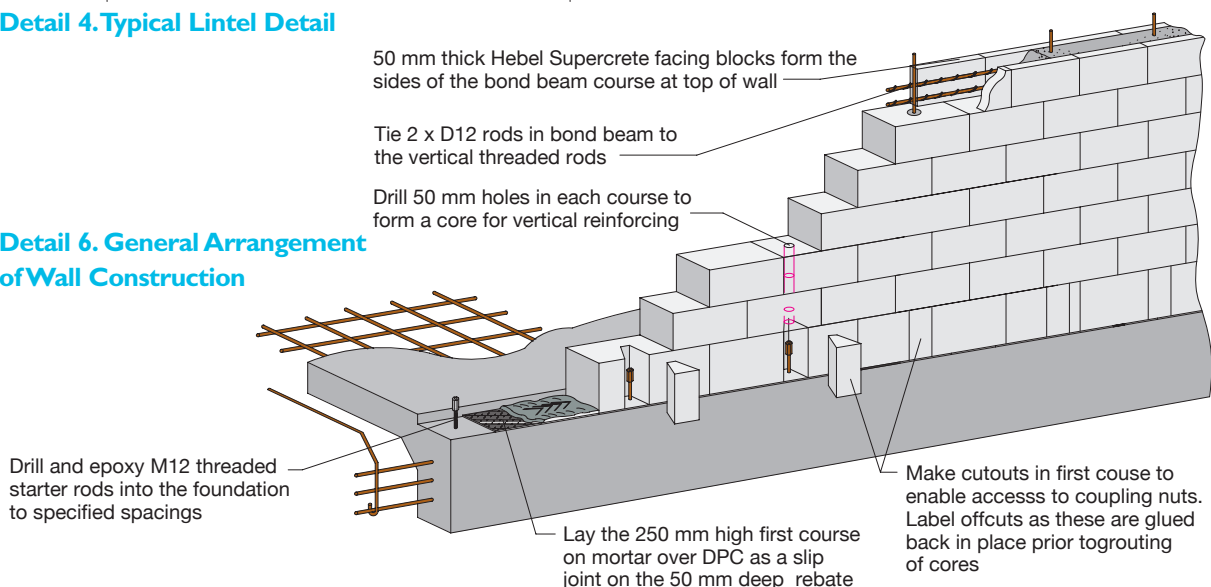

Drill and epoxy M12 threaded starter rods into the foundation to specified spacings

Lay the 250 mm high first course on mortar over DPC as a slip joint on the 50 mm deep rebate

Make cutouts in first course to enable access to coupling nuts. Label cutouts as these are glued back in place prior to grouting of cores

Tying two D12 horizontal bars to the protruding vertical rods then forms the bond beam, with 50 mm facing blocks glued to each side as permanent formwork with 15 MPa concrete poured between them.

Laying of blocks should not be carried out if there is a danger that the Supercoat Superbond Adhesive will freeze before curing.

If precast lintels are being used, these are laid the same as blocks during construction. If Lintels are being cast insitu, these can be constructed in the same manner as the bond beams, and are often formed by deepening of the bond beam over the opening, but with the addition of extra tension steel and shear reinforcement.

Control joints should have foam backing rods installed and the surface joint filled with Holdfast Fix All 220 LM MS, after first removing all surface dust for good adhesion.

Surfaces of walls should be sanded down flush with a sanding float and excess dust removed, prior to applying the surface finish.

Installation of Services

Hebel Supercrete Block construction allows for quick and efficient installation of services such as wiring and plumbing in any location on a wall. Chases no deeper than 1/3 of the wall thickness are cut into the wall using either hand or electric routers, or saw cuts. All wiring should be encased in conduit and after embedment in the wall, the chases are filled with Supercoat Superbond adhesive, thickened with the addition of Hebel Supercrete dust.



Supercoat Coating Systems

The surface of the Hebel Supercrete Block should be rendered or coated for waterproofing and to provide a more impact resistant surface. If Supercoat Superbase render is used, this can simply be finished with two or three coats of Supercoat paint. Tinting of the render with oxides is not recommended. If



very smooth surfaces are required on internal walls, it may be preferable to glue plasterboard directly on to the block and stop and paint. Note that Plasterboard may be glued directly over the movement control joints, if this is done. Please contact your Supercrete Distributor for Supercoat Coating System options.

Technical Support

CFG Concrete Ltd and its National Supercrete Distribution Network do not design Hebel Supercrete Block structures, as the design principles are no different to other solid masonry design. However, design information and technical support is freely available at both design and construction phases. On-site training is also available if required, to ensure that tradesmen are fully conversant with the construction method.

Thermal Performance

Hebel Supercrete Blocks have excellent thermal insulation properties due to their cellular structure with entrained air spaces. This means that supplementary insulation is unnecessary in most cases. Compared with traditional building materials, a Hebel Supercrete Block house will be much warmer in winter; and much cooler in summer. The New Zealand Building Code specifies a minimum R-value for solid masonry construction of between R 0.8 - R 1.2 depending on the Climate Zone within New Zealand (these values are lower than those required for timber framed construction as Masonry walls are homogeneous). A typical 200 mm rendered Hebel Supercrete Block wall has an R-value of 1.72, which is well in excess of code requirements.

The thermal properties of different wall thicknesses are shown in Table 1.

Acoustic Performance

Hebel Supercrete Block has very good acoustic properties and can significantly reduce the outside noise entering a building, and also room to room noise transmission. AAC has been shown to provide better insulation to sound transmitted by air, than other building materials such as concrete and clay bricks. The sound insulation of a material is primarily dependant on its weight per unit area, but AAC has shown higher than expected sound transmission losses which can be attributed to the internal material dampening i.e. AAC converts more acoustic energy into thermal energy than other building materials, due to its cellular structure.

The Sound Transmission Class for different wall thicknesses is shown in Table 1. Note that a typical timber framed insulated NZ house will have a STC rating of 20 to 24 decibels. Hebel Supercrete Blocks stop twice as much noise.

Autoclaved Aerated Concrete Wall Surface Temperatures

The effectiveness of Hebel Supercrete Block in controlling internal room temperatures was illustrated in tests by the Fraunhofer Institute for Architectural Physics in Germany. Surface temperatures were measured over a 24-hour period on a 250 mm thick Hebel Supercrete wall. The exterior of the wall was painted black to raise its surface temperature, which varied through a range of 70 degrees Celsius. The inside wall temperature remained at a comfortable 20 degrees Celsius with only a 2 degree variation. Test results are shown in the graph.

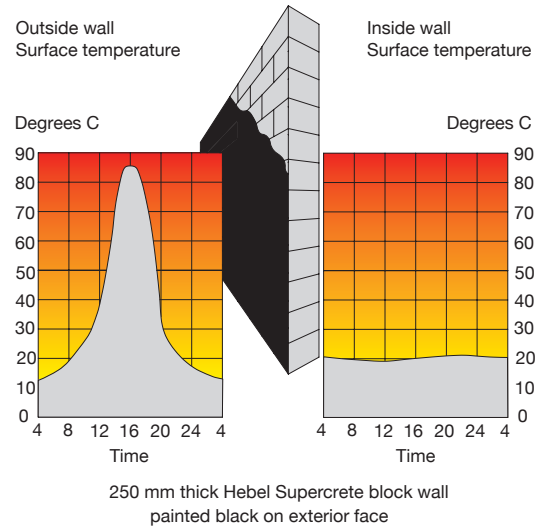
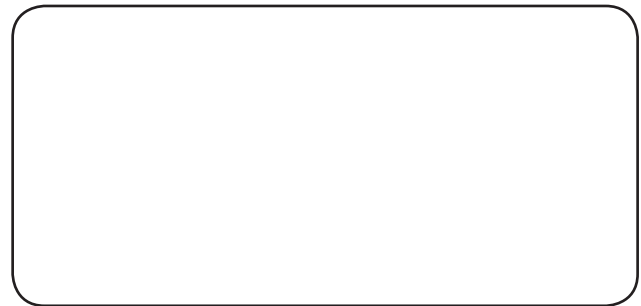

Table 1. Thermal and Acoustic Properties

Block Thickness mm	Block Only		Render on both sides		Render on one side and 10mm plasterboard on one side	
	R value m ² k/W	STC rating decibels	R value m ² k/W	STC rating decibels	R value m ² k/W	STC rating decibels
150	1.07	43	1.39	46	1.29	46
200	1.43	42	1.75	46	1.65	46
250	1.79	45	2.11	48	2.01	48
300	2.15	49	2.47	50	2.37	50

**For further information
on products and
our New Zealand wide
Distributor Network
Phone 0800 4 Hebel
or visit www.hebel.co.nz**

Authorised Distributor



CFG
COATINGS

67 Reid Rd, P.O. Box 2398
Dunedin, New Zealand.
Phone: +64 3 455 1502
Fax: +64 3 456 3587
0800 443 235
www.supercoat.co.nz

**For your nearest distributor of Hebel Supercrete Products
visit our website www.hebel.co.nz**

The information presented herein is supplied in good faith and to the best of our knowledge was accurate at the time of preparation. No responsibility can be accepted by CFG Concrete Ltd or its staff for errors or omissions. The provision of this information should not be construed as a recommendation to use any of our products in violation of any patent rights or in breach of any statute or regulation. Users are advised to make their own determination of the suitability of this information in relation to their particular purposes and specific circumstances. Since the information contained in this document may be applied in conditions beyond our control, no responsibility can be accepted by us for any loss or damage caused by any person acting, or refraining from action as a result of this information. The systems detailed in this design guide are only to be used with Hebel Supercrete products manufactured by CSR Hebel Australia and distributed by CFG Concrete Ltd. This literature is not permitted to be used for other types of AAC, including Hebel Supercrete AAC from other manufacturers.