

Accessible Stairway 32° max

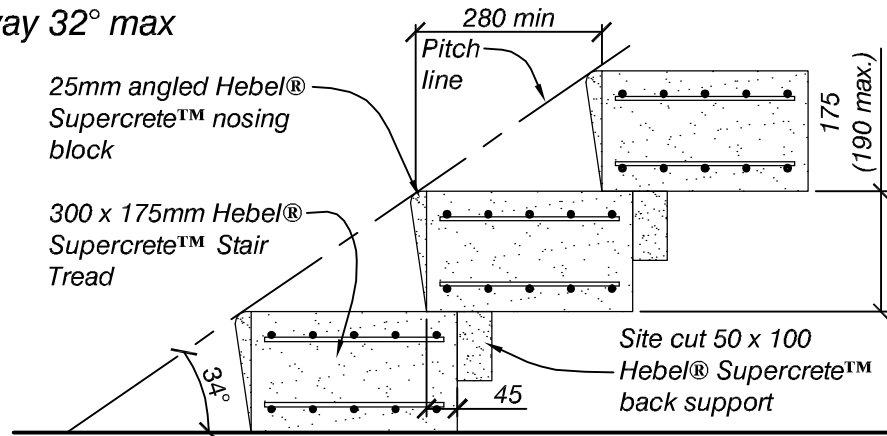

Common Stairway 37° max

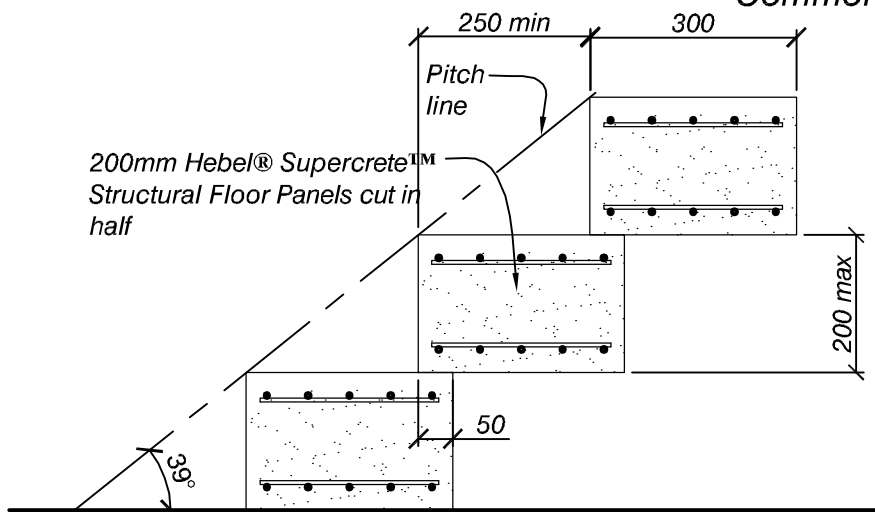

Secondary Stairway 41° max

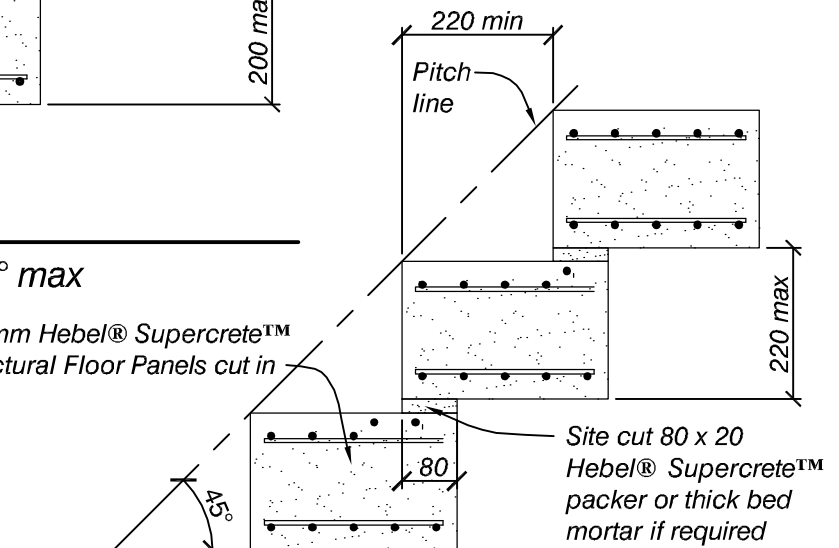

Service Stairway 47° max

Hebel
Supercrete

Title: Pitch, Riser & Treads for Hebel® Supercrete™
Stair Treads to meet the NZ Building Code

Date: October 2011

Scale: N.T.S.

Detail No. SFP 5-1

This drawing must be read in conjunction with all the Hebel Supercrete Structural Floor Panels Design Guide